

UDC 622.823

Lovejkin V. S., Chovnjuk Y. V., Sachyk A. P.

**THE CRANE'S VIBRATING SYSTEMS CONTROLLABLE BY MECHATRONICS' DEVICES WITH MAGNETORHEOLOGICAL FLUID: THE NONLINEAR MATHEMATICAL MODEL OF BEHAVIOR AND OPTIMIZATION OF WORK REGIMES**

It is known that magnetorheological (MR) and electrorheological (ER) fluids may be used for the crane's vibrating systems controllable by mechatronics' devices.

Magnetorheological fluids are suspensions consisting of ferromagnetic particles in a low permeability base liquid, usually oil (in some cases water) with surfactants to prevent sedimentation. Electrorheological fluids are suspensions of electrostatically polarizable particles. Very fast reversible changes (usually in milliseconds) of rheological properties, especially apparent viscosity and elasticity are caused by the polarization induced in the suspended particles under applied external magnetic flux or electrical field. The particle chain formation and later changes from chains to columns are observed. This is known as the rheological effect. Thus MR or ER fluids behave as a Newtonian liquid (if base fluid has this property) without the presence of polarizing magnetic flux or electrical field and as a semi-solid when exposed to the field. This phenomenon is associated with changes of yield stress of the suspension. In effect, external field fluid strength changes according to applied external field. This fluid (or suspension) under an external field behaves as a Bingham semi-plastic until the shear stress becomes equal to the yield stress, which begins the onset of flow. The ER fluid behaves in the same manner as the MR fluid when as external electrical field is applied.

The known applications of MR fluids are in brake/clutch design [4], valves [16], engine mounts [3] and in vibration dampers [2, 7, 10, 11].

Early investigations of sound transmission loss (STL) in the stiffness controlled space between two barriers with ER fluid between them under DC and AC voltage [12, 13] shows, that due to increased mechanical coupling strength, the STL decreases. The STL was investigated for various kinds of ER suspensions in the frequency range from 100 Hz up to 2 kHz. Laboratory results showed that the normal stress developed in ER fluid has a significant influence on the magnitude of STL. The tangential (shear) stress had a negligible effect on the STL.

As an example, in Fig. 5, the (crane's) vibration of a two degree of freedom system with a MR damper is used to illustrate the separation of the vibrating excitation source from the system to reduce the negative effect from the unwanted crane's vibrations. This is very common example of an airplane taxiing over a wavy surface of a runway or a vehicle driving over a wavy road surface. The MR fluid (MRF) damper in this suspension design is used to separate, to some extent, motion of mass  $m_1$  which represents wheel with attached masses, from  $m_2$ , which is airplane or vehicle body mass. This RF damper, with a controlled value for its damping factor by associated control system (such as mechatronics control system), allows optimizing for minimization of the amplitude of motion or force transmitted to the airplane or vehicle body. The passive, the most common design, vibration suspension works in optimal conditions only when the mass of the system varies in a narrow range and in a certain frequency space. To improve/expand suspension performance over a wide range of payloads and frequencies, the active vibration control technique can be used, however, associated with this design, complexity, cost and power requirements limits its application. With some compromises in crane's control effectiveness, the active vibration control system can be replaced by a semi-active vibration control system of the crane. In many practical applications semi-active vibration control systems can be nearly as effective as active vibration control systems used in some passenger vehicles. The positive characteristics of this system are:

1. The semi-active system/suspension still works in a passive regime even when the control system and/or power supply fails.
2. The power requirements to control the damping force of the damper with rheological fluid (RF) are relatively low.
3. By using MR fluid in a damper, a common passenger vehicle 12 V DC electrical system is sufficient to create effective the damping force. The force controlling the electrical current usually doesn't exceed a few amperes.

In this paper the nonlinear mathematical model of the behavior of a MR fluid in a crane's vibration system damper under an applied external magnetic flux density is presented. The equivalent apparent variable damping factor, related to the apparent viscosity, based on the equivalent energy dissipated principle was calculated.

The purpose of the article.

The purpose of this article is to justify the nonlinear mathematical model of behavior and optimization of work regimes for the crane's vibrating systems controllable by mechatronics' devices with magnetorheological fluid.

The presentation of fundamental results.

Response of the crane's vibration system damper with a rheological fluid to the external field.

The principle of application of a magnetorheological fluid in damper design to control the magnitude of a damping force  $F_d$  in the crane's vibration system by applying electromagnetic field resulted from electrical current ( $i$ ) flowing in coils around piston's orifices is shown in Fig. 1. The response of the damper under an applied external field in this example results from the changes in apparent viscosity of the MRF suspension.

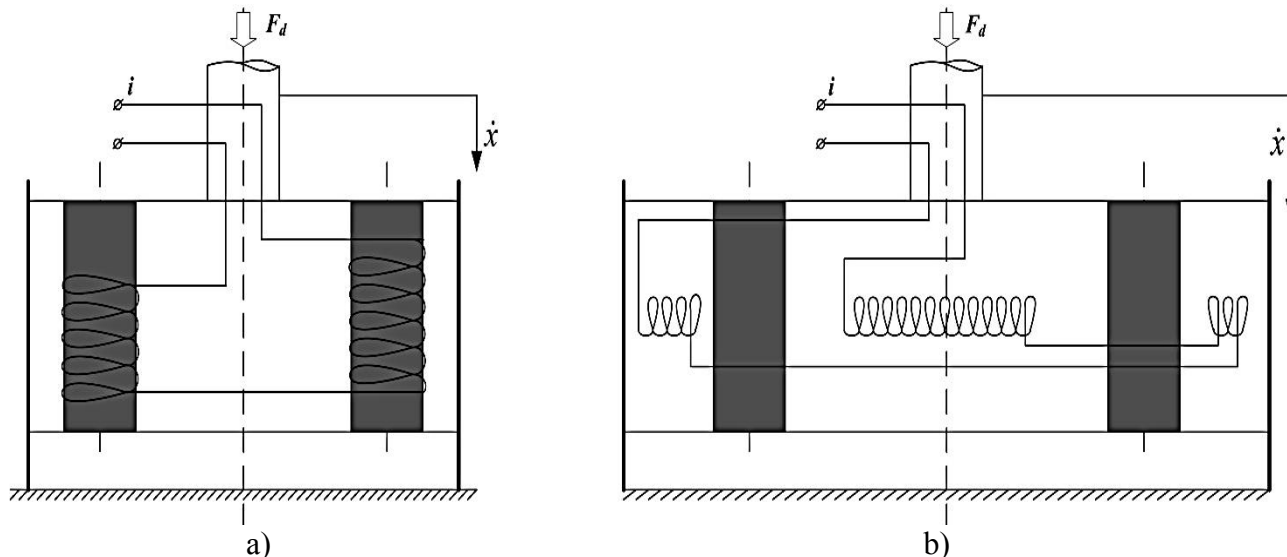

Fig. 1. The principle to control damping force  $F_d$  by applying variable electrical current  $i$  to change the apparent viscosity of the MRF in the orifices:

a – tangential stress control; b – normal stress control

The damping force  $F_d$  is proportional to the apparent viscosity of the RF in the orifices and its velocity ( $\dot{x}$ ). The viscosity (after I. Newton) is described as a relationship between shear stress in a fluid ( $\tau$ ) and observed velocity gradient ( $\partial\dot{x}/\partial h$ ) in a fluid subjected to motion. Characteristics  $\tau_{RF} = f(\dot{x})$  of a typical MRF are shown in Fig. 2. In the absence of an applied external field the RF often exhibits Newtonian – like behavior associated mostly with the base fluid physical properties. An applied external field changes this behavior and the rheological fluid in the piston's

orifices shows a variable yield stress which depends on the strength of that field. The apparent shear stress of the RF depends of two components. One of them is Newtonian, proportional to the viscosity of the base fluid and velocity gradient. The second is controllable by the applied external field. The controllable external field stress shown in Fig. 1, b is significantly higher in amplitude than in the design shown in Fig. 1, a.

Equation (1) describes the property of apparent shear stress observed in the piston’s orifices when an external field is applied.

$$\tau(RF_i) = \tau_0(RF_i) + \eta \cdot \left(\frac{\partial \dot{x}}{\partial h}\right), \tag{1}$$

where yield stress  $\tau_0(RF_i)$  as a function of the external field caused by the magnetic flux density for  $\dot{x} = 0$  and Newtonian shear stress  $\eta \cdot \left(\frac{\partial \dot{x}}{\partial h}\right)$  proportional to dynamic viscosity of the base fluid  $\eta$  and velocity gradient  $\frac{\partial \dot{x}}{\partial h}$ .

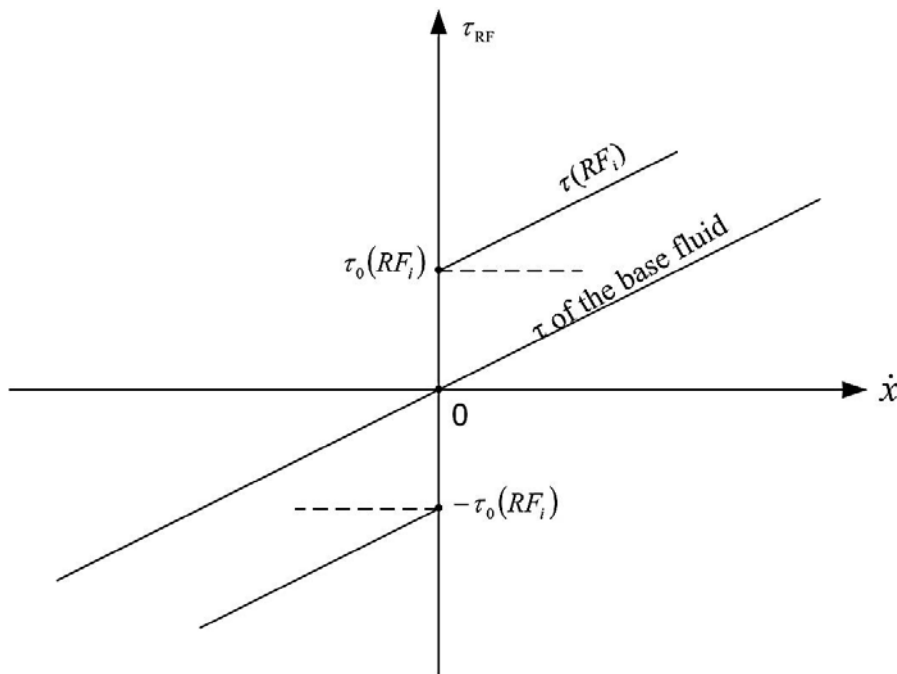

Fig. 2. The shear stress versus velocity of a MRF under applied electromagnetic field represented by current  $i$

In the absence of the external field, the shear stress  $\tau(RF_i)$  of the rheological fluid behaves viscoelastically. Fig. 2 shows the behavior of the apparent shear stress of a rheological fluid in a damper under an applied external electrical or electromagnetic field. The electromagnetic field can also be represented by the electrical current  $i$  flowing in coils placed around piston’s orifices.

According to Fig. 2 the shear stress of a RF can be expressed as:

$$\tau(RF_i) = \tau_0(RF_i) + \frac{\partial \tau_{RF_i}}{\partial \dot{x}} \cdot \dot{x}. \tag{2}$$

The equivalent damping factor  $C_{RF}$ , is:

$$C_{RF_i} = \left[ \left\{ \tau_0(RF_i) + \frac{\partial \tau_{RF_i}}{\partial \dot{x}} \cdot \dot{x} \right\} \cdot A \right] \cdot \frac{1}{\dot{x}}, \tag{3}$$

where  $A$  – is chosen oblique area.

The damping force  $F_{di}$  at point of work is:

$$F_{di} = \tau(RF_i) \cdot A. \tag{4}$$

The ratio of:

$$\frac{\partial \tau_{RF_i}}{\partial \dot{x}} = f[\tau_0(RF_i)], \tag{5}$$

need to be established experimentally.

RF damper model for the crane’s vibration system.

The balance of internal damper forces in equilibrium with an external force (free body diagram) of a RF damper of the crane’s vibration system is shown in Fig. 3. The complex damping force  $F_{di}$  (which is also a response force from the damper in motion) has two components,  $F_{d\eta}$ , which depends on a damping constant  $C_\eta$  (related to the piston’s orifice design and physical properties of the base fluid) and velocity  $\dot{x}$ , and  $F_{doi}$ , which depends only on the external, in this case electromagnetic field, represented by electrical current  $i$ . In the absence of an external electromagnetic field and/or current  $i$ , the internal force  $F_{doi}$  becomes zero and the damping force becomes  $F_{di} = F_{d\eta}$ .

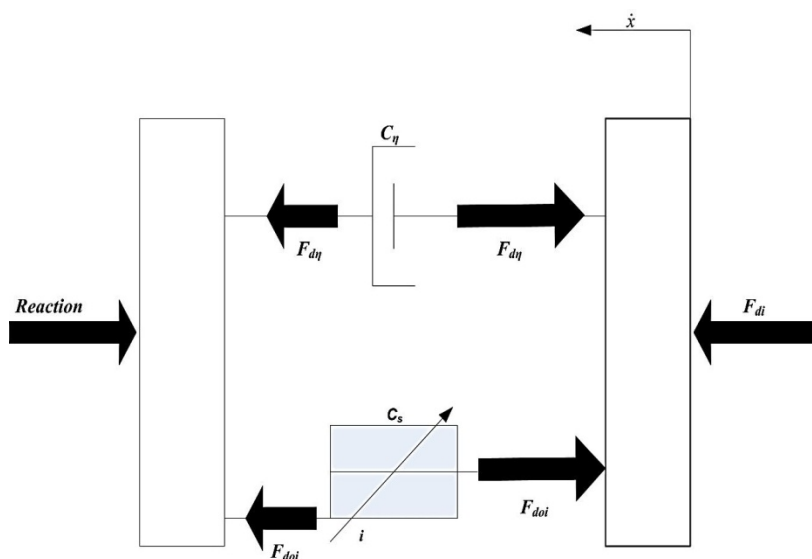

Fig. 3. Model of the rheological fluid damper for a crane’s vibration system, where viscous damping force is  $F_{d\eta} = C_\eta \cdot \dot{x}$  and damping force controlled by external field is  $F_{doi} = F_{do}(RF) \cdot \text{sgn}(\dot{x})$ . The  $C_s$  represents the apparent damping coefficient of the RF under an external field and  $F_{do}$  represents the offset damping force when  $\dot{x} = 0$

The relationship between force, shear stress and velocity is called the Rheological Fluid Model and can be expressed in the general form as:

$$F_{di} = \begin{cases} \tau_0(RF_i) \cdot A + \frac{\partial_i RF}{\partial \dot{x}} A \dot{x} & \dot{x} > 0, \\ 0 & \dot{x} = 0, \\ -\tau_0(RF_i) \cdot A + \frac{\partial_i RF}{\partial \dot{x}} A \dot{x} & \dot{x} < 0. \end{cases} \tag{6}$$

Considering that:

$$\tau_0(RF) \cdot A = F_{do}(RF), \tag{7}$$

represents damping force controlled by external field and:

$$\frac{\partial \tau_{RF}}{\partial \dot{x}} A \dot{x} = F_{d\eta}, \tag{8}$$

which represented damping force proportional to the velocity  $\dot{x}$  (see Fig.3) and is:

$$F_{di} = F_{doi} + F_{d\eta}, \tag{9}$$

represents the complex damping force.

Response of the crane's vibrating system with RF damper

One degree of freedom crane's vibrating system with RF damper

The free body diagram of a one degree of freedom (1DOF) crane's vibrating system with a RF damper is shown in Fig. 4.

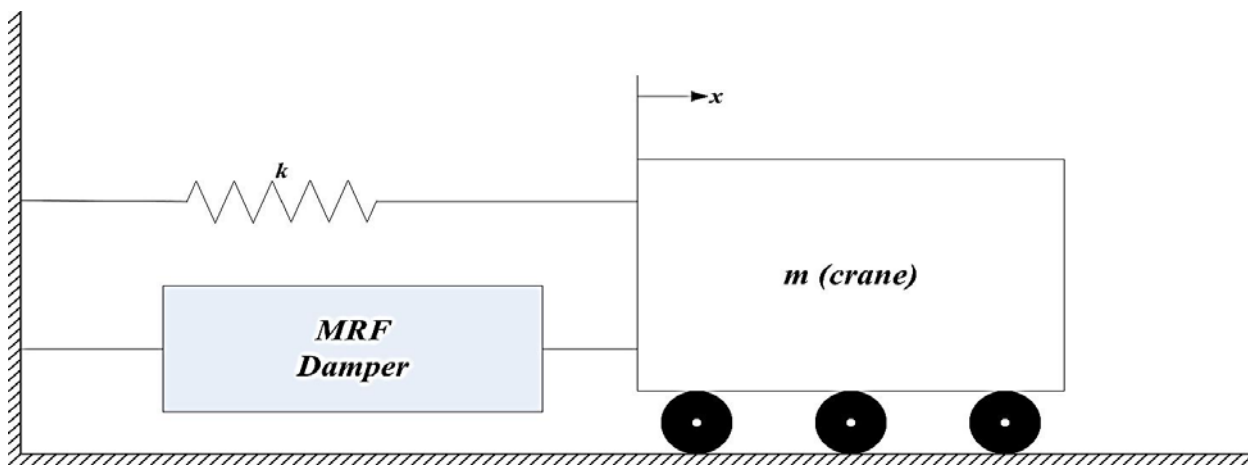

Fig. 4. Model of a 1DOF of crane's vibrating system with a RF damper, where m is mass and k is stiffness

In this model the instantaneous equilibrium of forces is:

$$m\ddot{x} + C_{\eta} \cdot \dot{x} + F_{do}(RF) \cdot \text{sgn}(\dot{x}) + kx = 0, \tag{10}$$

where

$$C_{\eta} \cdot \dot{x} + F_{do}(RF) \cdot \text{sgn}(\dot{x}) = F_d, \tag{11}$$

is the complex damping force.

This can be expressed as a product of equivalent damping  $C_{eq}$  and velocity  $\dot{x}$ :

$$F_d = C_{eq} \cdot \dot{x}. \tag{12}$$

Two degree of freedom crane's vibrating system with base excitation and RF damper

This model represents two degree of freedom (2DOF) crane's vibrating systems with a base excitation system, having stiffness  $k_1$  and mass  $m_1$  in the first stage and connected by a spring with stiffness  $k_2$  and a parallel attached controllable (by mechatronic system) MR damper to the second mass  $m_2$ .

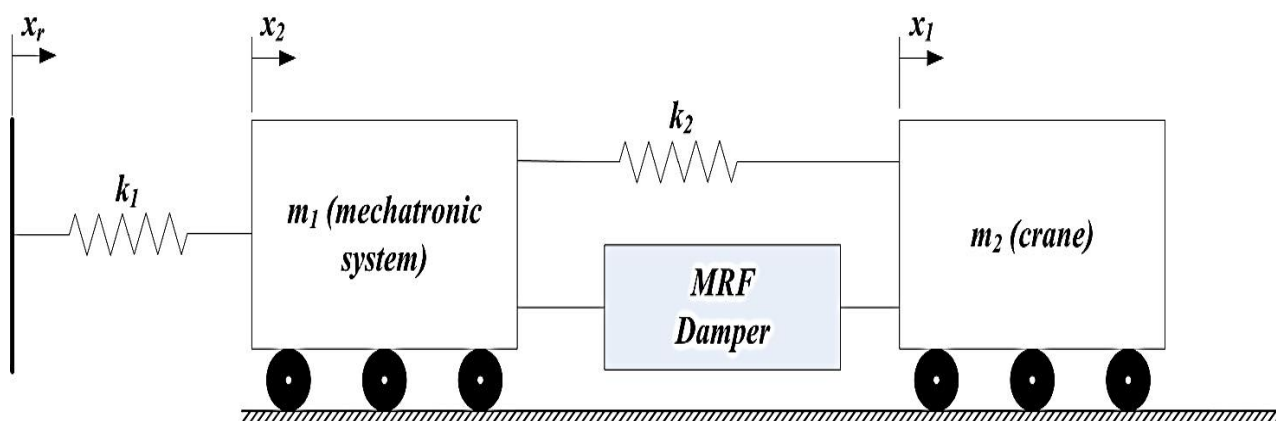

Fig. 5. The model of two degree of freedom crane’s vibrating system with base excitation

Behavior of this two degree of freedom crane’s vibrating system can be described by a set of two equations which are the instantaneous equilibrium of the acting forces:

$$\begin{cases} m_2 \cdot \ddot{x}_2 = (x_1 - x_2) \cdot k_2 + (\dot{x}_1 - \dot{x}_2) C_{RF}, \\ m_1 \cdot \ddot{x}_1 = (x_2 - x_1) \cdot k_2 + (\dot{x}_2 - \dot{x}_1) C_{RF} + (x_2 - x_1) \cdot k_1, \end{cases} \quad (13)$$

where

$$(\dot{x}_2 - \dot{x}_1) \cdot C_{RF} = F_d, \quad (14)$$

represents the magneto-rheological damping force.

The rheological complex damping coefficient complex damping coefficient ( $C_{RF}$ ) depends on the mechanical and electrical design of the damper and rheological fluid used.

Equivalent damping in the crane’s vibrating system

The response of the 1DOF crane’s vibrating system with RF damper presented in Fig. 4 under harmonic excitation force  $F_0 \cdot \sin \omega t$  applied to mass  $m$  is:

$$m\ddot{x} + F_{do}(RF) \cdot \text{sgn}(\dot{x}) + C_\eta \cdot \dot{x} + kx = F_0 \cdot \sin(\omega t). \quad (15)$$

In this equation the damping force has two components.

One of them is a Newtonian type and it is proportional to the velocity  $\dot{x}$ , and a second, a semi Bingham one, which depends on the strength of the external field and direction of motion expressed by  $\text{sgn}(\dot{x})$ .

The energy dissipated,  $\Delta E_\eta$  in the viscously damped system per one cycle with viscous damping coefficient  $C_\eta$  is:

$$\Delta E_\eta = \oint F_{d\eta} dx = \int_0^{2\pi/\omega} C_\eta \cdot \dot{x} \cdot \frac{dx}{dt} dt = \int_0^{2\pi/\omega} C_\eta \cdot \dot{x}^2 dt. \quad (16)$$

Substituting  $x = X \cdot \sin(\omega t)$  and  $\dot{x} = \omega X \cdot \cos(\omega t)$  into above equation,

$$\Delta E_\eta = C_\eta \cdot \int_0^{2\pi/\omega} [\omega^2 \cdot X^2 \cdot \cos^2(\omega t)] dt, \quad (17)$$

then integrating, results in:

$$\Delta E_\eta = C_\eta \cdot \pi \cdot \omega \cdot X^2. \quad (18)$$

The second damping component represented by force,  $F_{do}(RF)$  in Eq.(9) yields the following expression for dissipated energy:

$$\Delta E(RF) = F_{do}(RF) \cdot \int_0^{2\pi/\omega} [\text{sgn}(\dot{x}) \cdot \dot{x}] dt. \quad (19)$$

Then dissipated energy in one cycle of the damper becomes:

$$\Delta E(RF) = F_{do}(RF) \cdot X \cdot \left[ \int_0^{\pi/2} \cos(\omega t) d(\omega t) - \int_{\pi/2}^{3\pi/2} \cos(\omega t) d(\omega t) + \int_{3\pi/2}^{2\pi} \cos(\omega t) d(\omega t) \right] \quad (20)$$

Solving the integration yields that the energy dissipated by a controllable by mechatronic system damping force  $F_{do}(RF)$  is:

$$\Delta E(RF) = 4 \cdot F_{do}(RF) \cdot X. \quad (21)$$

To create a viscously damped system of equivalent energy loss, we obtain:

$$\pi \cdot C_{eq} \cdot \omega \cdot X^2 = 4 \cdot F_{do}(RF) \cdot X + C_{\eta} \cdot \pi \cdot \omega \cdot X^2. \quad (22)$$

Thus the equivalent damping coefficient  $C_{eq}$  yields:

$$C_{eq} = \frac{4F_{do}(RF) \cdot X + C_{\eta} \cdot \pi \cdot \omega \cdot X^2}{\pi \omega X^2}. \quad (23)$$

In terms of equivalent damping ratio  $\xi_{eq}$ :

$$C_{eq} = 2 \cdot \xi_{eq} \cdot \omega_n \cdot m \quad (24)$$

and

$$\xi_{eq} = \frac{4 \cdot F_{do}(RF) \cdot X + C_{\eta} \cdot \pi \cdot \omega \cdot X^2}{2\pi \cdot \omega \cdot \omega_n \cdot X^2}. \quad (25)$$

The 1DOF crane's vibrating system with equivalent damping  $C_{eq}$  which will dissipate as much energy as the system described by Eq. (10) is:

$$\ddot{x} + 2\xi_{eq} \cdot \omega \cdot \dot{x} + \omega_n^2 \cdot x = f_0 \cdot \sin(\omega t), \quad (26)$$

where  $f_0 = F_0/m$  and  $\omega_n = \sqrt{k/m}$ .

This is also an approximation of the Eq. (15).

### CONCLUSION

In this paper the analytical model of rheological fluid was formulated and the equivalent coefficient of damping of the damper with a magneto-rheological (MR) fluid based on the dissipated energy principle was calculated. The major parameter in these calculations is apparent viscosity associated with shear stress of the MR fluid under an applied external field. This equivalent coefficient of damping allows the performance of crane's vibration calculations and the design of mechanical systems to control with a help of mechatronic devices unwanted crane's vibrations in wider

payload and frequency range that the crane's system with uncontrollable damping. In addition, when a variable strength external field synchronized with the period of crane's system oscillations is applied an almost unlimited characteristic of a damping force can be obtained. The rheological phenomenon can also be used to control sound transmission loss of a multibarrier system with rheological fluid placed between them. The increasing mechanical strength of the fluid between barriers increases apparent/equivalent stiffness of the system, thus the control of sound transmission loss in a stiffness control space is achievable.

#### REFERENCES

1. Carlson J. D. (2008), *Magnetorheological fluids*, in : *Smart Materials*, CRC Press, New York, NY. USA.
2. Carlson J. D., Cantanzarite D. M., Clair K. A. S. (1996), *Commercial magnetorheological fluid devices*, *International Journal of Modern Physics B*, vol.10, P. 23–24, 2857-2865.
3. Choi S. B., Hong S. R., Sung K. G., Sohn J. W (2008), *Optimal control of structural vibrations using a mixed-mode magnetotheological fluid mount*, *International Journal of Mechanical Sciences*, vol. 50, P. 559–566
4. Choi S. B., Hong S. R., Cheong C. C., Park Y. K. (1999), *Comparison of field-controlled characteristics between ER and MR clutches*, *Journal of Intelligent Material Systems and Structures*, vol.10, p.p. 615-619.
5. Ginder J. M., Davis L. C, Elie L. D. (1995), *Rheology of Magnetorheological Fluids. Modes and Measurements*, 5<sup>th</sup> Int. Conf. On ERF, MRS and Their Applications, Univ. Sheffield, UK.
6. Jolly M. R., Carlson J. D., Munoz B. C. (1996), *A Model of the Behavior of Magnetorheological Materials*, *Smart Materials and Structures*, vol.5, P. 607–614.
7. Kamath G. M., Wereley N. M., Jolly M. R. (1999), *Characterization of magnetorheological helicopter lag dampers*, *Journal of the American Helicopter Society*, vol.44, P. 234–248.
8. Kordonsky W. (1993), *Magnetorheological Effect as a Base of New Devices and Technologies*, *Journal of Magnetorheology and Magnetorheological Materials*, vol. 122, P. 395–398.
9. Nakano M. H., Yamamoto M. R., Jolly M. R. (1997), *Dynamic Viscoelasticity of a Magnetorheological Fluid in Oscillatory Slit Flow*, 6<sup>th</sup> Int. Conf. on ERF, MRS and Their applications, Yonezawa, Japan.
10. Pang L., Kamath G. M., Wereley N. M. (1997), *Analysis and Testing of a Linear Stroke Magnetorheological Damper*, *AIAA/ASME Adaptive Structures Forum*, Paper No. AIAA 98-2040, Long Beach, CA.
11. Spencer Jr. B. F., Dyke S. J., Sain M. K., Carlson J.D. (1997), *Phenomenological model for a magnetorheological damper*, *Journal of Engineering Mechanics ASCE*, vol.123, P. 230–238.
12. Weiss K. D., Duclos T., Carlson J. D., Chrzan J. M., Margida A. J. (1993), *High Strength Magneto- and Electrorheological Fluids*, *Society of Automotive Engineers*, SAE Paper 932451.
13. Weiss K. D., Carlson J. D., Nixon D. A. (1994), *Viscoelastic Properties of Magneto- and Electrorheological Fluids*, *Journal of Intelligent Material Systems and Structures*, vol.5, P. 772–775.
14. Yoo J. H., Wereley N. M. (2002), *Design of a high efficiency magnetorheological valve*, *Journal of Intelligent Material Systems and Structures*, vol.13, P. 679–685.